

CRW800H20 Water Rowing Machine
OWNER'S MANUAL

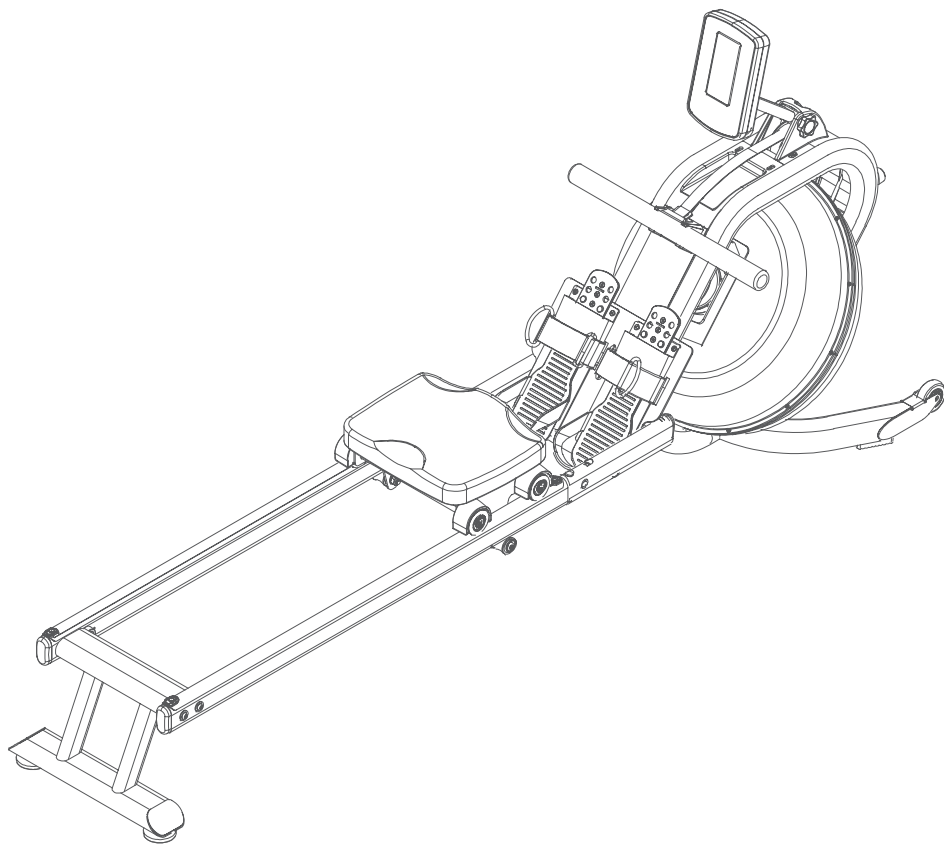

TABLE OF CONTENTS

6	REGISTER YOUR PURCHASE
7	IMPORTANT SAFETY INSTRUCTIONS
8	WARNING LABELS AND COMMUNICATION STICKERS
9	SAFEGUARDS
11	CRW800H2O ASSEMBLY INSTRUCTIONS
18	TANK FILLING & WATER TREATMENT PROCEDURES
21	CONSOLE OPERATION
31	ENGINEERING MODE
32	GENERAL MAINTENANCE
34	TROUBLESHOOTING
35	MANUFACTURER'S LIMITED WARRANTY

Thank you for purchasing our product, please save these instructions. Please do not perform or attempt any customizing, adjustments, repair or maintenance that is not described in this manual.



Congratulations on your new CRW800H2O Water Rowing Machine and welcome to the Spirit Fitness family!

Thank you for your purchase of this quality CRW800H2O Water Rowing Machine from Spirit Fitness. Your new CRW800H2O was manufactured by one of the leading fitness manufacturers in the world and is backed by one of the most comprehensive warranties available. Through your dealer, Spirit Fitness will do all we can to make your ownership experience as pleasant as possible for many years to come. If not purchased direct from Spirit Fitness, the local dealership where you purchased this rower is your administrator for all Spirit Fitness warranty and service needs. Their responsibility is to provide you with the technical knowledge and service personnel to make your experience more informed and any difficulties easier to remedy.

Please take a moment at this time to record the name of the dealer, their telephone number, and the date of purchase below to make any future, needed contact easy. We appreciate your support and we will always remember that you are the reason that we are in business.

Yours in Health,
Spirit Fitness

NAME OF DEALER _____

DEALER PHONE # _____

PURCHASE DATE _____

RECORD YOUR SERIAL NUMBER

Please record the serial number of this fitness product in the space provided below (serial number is located on the center floor tube behind the crank).

Serial Number:

REGISTER YOUR PURCHASE

The self-addressed product registration card must be completed in full and returned to Spirit Fitness. You can also go to <https://www.spiritfitness.com/commercialwarrantyregistration.html> under the "Support" tab to register online.

IMPORTANT SAFETY INSTRUCTIONS

WARNING

This chapter includes precautions and fitness safeguards for the installation and use of the Water Rowing Machine manufactured by SPIRIT FITNESS. Please read this chapter carefully before installing or using your equipment.

USER SAFETY PRECAUTIONS

These safety notes are directed to you as the owner of the Water Rowing Machine manufactured by Spirit Fitness. Please train all your users and fitness staff to follow these safety instructions.

DO:

- Do encourage each of your users to discuss their health program or fitness regimen with a healthcare professional.
- Do stop operating your rower if you feel dizzy or faint.
- Do perform regular preventative maintenance.
- Do exercise slowly until you reach a level of comfort.

DO NOT:

- Do not let unsupervised children operate the rower.

- Do not use without proper athletic shoes.
- Do not use in rainy weather outdoors, or in an enclosed pool environment.
- Do not drop or insert any object, hands, or feet into any opening or within the area operation of the product.
- Do not attempt to remove any shrouds or modify the rower.

WARNING:

- Your Water Rowing Machine manufactured by Spirit Fitness is designed for exercise in a commercial or consumer environment.
- Please check with your physician prior to beginning any exercise program.
- Do not push yourself to excess. Stop if you are feeling faint, dizzy, or exhausted. Use common sense when rowing.
- Read the owner's manual in its entirety before operating the rower.
- Failure to obey this warning can result in injury or death.

SPIRIT FITNESS® and the Spirit Fitness logo are registered trademarks of Dyaco International.

WARNING LABELS AND COMMUNICATION STICKERS

The image below shows an example of Spirit® Fitness warning labels and communication stickers placed on the equipment as part of the manufacturing process. It is critical that owners maintain the integrity and placement of these stickers. If you find any stickers missing or damaged contact your local dealer or distributor for a replacement. *NOTE: STICKERS AND LABELS ARE NOT SHOWN TO SCALE.*

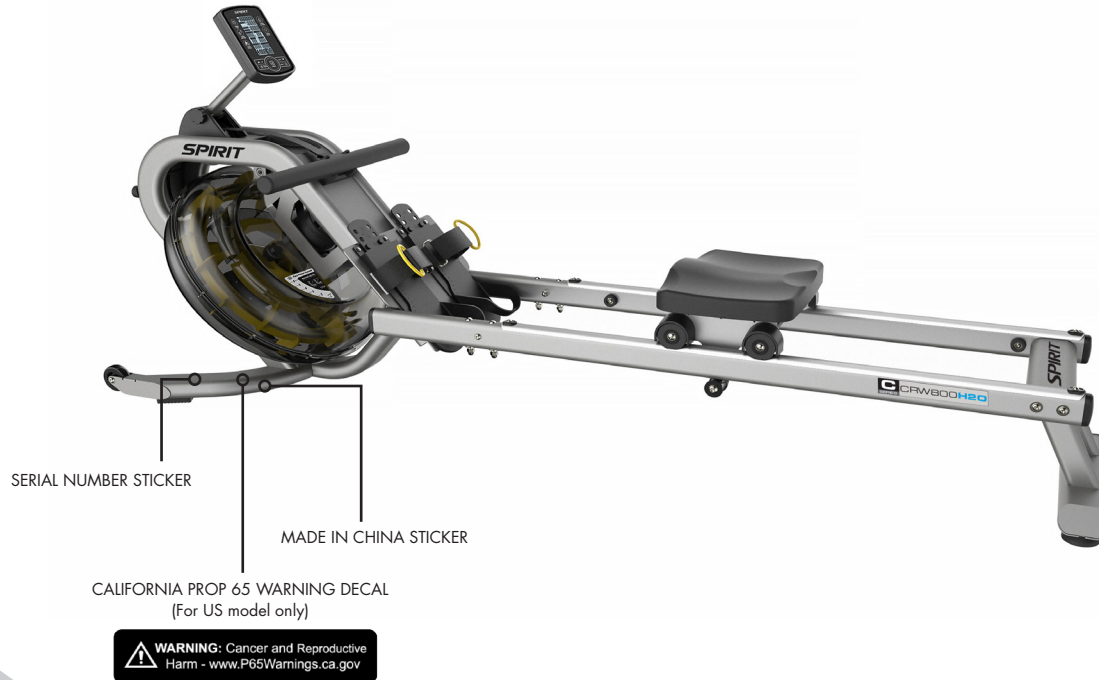

SAFEGUARDS

The following fitness safeguards and operating precautions are directed to purchasers and users of the Water Rowing Machine. Club Managers should ensure that members and fitness staff are trained to follow these same instructions. Failure to follow these safeguards may result in injury or serious health risk.

- Do not use any equipment in any way other than designed or intended by the manufacturer. It is imperative that equipment is used properly to avoid injury.
- Injuries may result if exercising improperly or excessively. It is recommended that all individuals consult a physician prior to commencing an exercise program.
- If at any time during exercise you feel faint, dizzy or experience pain, stop exercising and consult your physician.
- Keep body parts (hands, feet, hair, etc.), clothing and jewelry away from moving parts to avoid injury.
- Follow instructions provided in this manual for correct foot position and basic rowing techniques.
- **The maximum weight for individuals riding the rower should not exceed 350 lbs.**
- Do not use or permit use of any equipment that is damaged and/or has worn or broken parts. For all equipment use only replacement parts supplied by Spirit Fitness.
- Cables and belts pose an extreme liability if used when frayed. Always replace any cable or belt at first sign of wear (consult Spirit Fitness if uncertain).
- Preventative maintenance is the key to smooth operating equipment as well as to keep your liability to a minimum. Equipment needs to be inspected at regular intervals.
- Ensure that any person(s) making adjustments or performing maintenance or repair of any kind is qualified to do so.
- Do not attempt to use or repair any accessory approved for use with the Spirit Fitness Equipment which appears to be damaged or worn.
- Check all belts, pulleys and bungee cords regularly for signs of wear, and replace if needed.
- Check regularly and follow all instructions for maintenance as specified in this manual.
- Replace immediately any defective parts and do not operate unit until all repairs are complete.
- Keep children away from the equipment. Parents or others supervising children must provide close supervision of children if the equipment is used in the presence of children.

- Do not allow users to wear loose fitting clothing or jewelry while using equipment. It is also recommended to have users' secure long hair back and up to avoid contact with moving parts.
- All bystanders must stay clear of all users, moving parts and attached accessories and components while machine is in operation.
- We recommend an area no less than 2ft kept clear around the rower for easier access and safety.

WARNING

This product can expose you to chemicals including Toluene and Acrylamide which are known to the State of California to cause Cancer and birth defects or other reproductive harm. For more information, go to www.P65Warnings.ca.gov

WARNING

Do not insert fingers into tank.

WARNING

After rowing exercise, please allow the unit to sit for 5 minutes before standing it up for storage.

WARNING

Do not fill past the calibration mark as indicated on the tank level sticker or water spillage can occur.

WARNING

Never operate this rower without feet properly secured in foot straps, or without the sliding portion of the slider footplate locked into position.

Note: Rower is not suitable for therapeutic purposes.

CRW800H20 PRE-ASSEMBLY

Use the following procedures to unpack and assemble your Water Rowing Machine manufactured by Spirit Fitness:

1. Position the shipping carton so the heavy end is located at the bottom.
2. Cut the straps then lift the box over the unit and unpack. Remove foam inserts and all parts from the shipping carton, then use the parts list to verify that all parts are included in your shipment.
3. Locate the hardware package. The hardware is separated into steps. Remove the tools first. Remove the hardware for each step as needed to avoid confusion. As you read through the assembly instructions, any number that is in brackets [#] refers to the item number from the corresponding assembling drawing.

NOTE: All tools required to assemble the rower are included within the packaging.

NOTE: If you are missing any of the parts listed above, inspect the packing material and the box for items that may have been overlooked.

If parts are missing, or if you have any operational questions, please call your local Spirit Fitness's service department or the distributor whom sold you the product. Please see the back of the manual for a listing of international corporate offices and locate the office nearest you. Have your serial number ready.

CAUTION: Damage to the rower during assembly is not covered as part of the limited Spirit Fitness warranty. Take care not to drop or lean the rower on its side. Carefully stand the rower up in the normal upright position on a stable surface so it will not tip over during assembly.

Protect the environment by not disposing of this product with household waste. Check your local authority or approved waste center for recycling advice and facilities.

CRW800H20 ASSEMBLY PARTS CHECKLIST

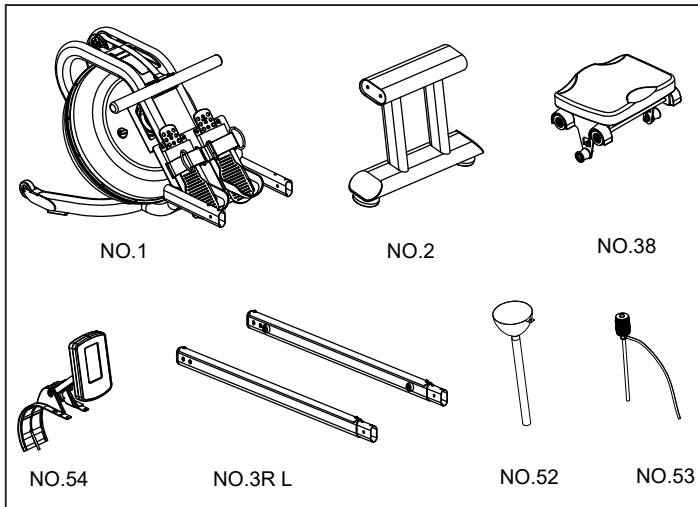



Note: Above parts are all needed to assemble this machine.
Before you start to assemble, please check the hardware packing to make sure they are included.

Part No	Description	Q'ty
1	Main Frame	1
2	Rear Stabilizer	1
3R/3L	Slide Rail	1/1
38	Seat Assembly	1
54	Computer Assembly	1
52	Funnel	1
53	Pumping Siphon	1
	Water-Purification Tablet	1
	User Manual	1
	Hardware Parts	1
	AA Batteries	4

CRW800H20 PARTS

 # 63 M8*45 4pcs

 #65 M6*15 6pcs

 #68 M8*15 4pcs

 #74 OD20*ID8.5*1.5 4pcs

 # 77 M8*27 2pcs

 #93 S5 1pc

 #94 S13-17 1pc

 # 99 M8*57 4pcs

CRW800H20 STEP ONE

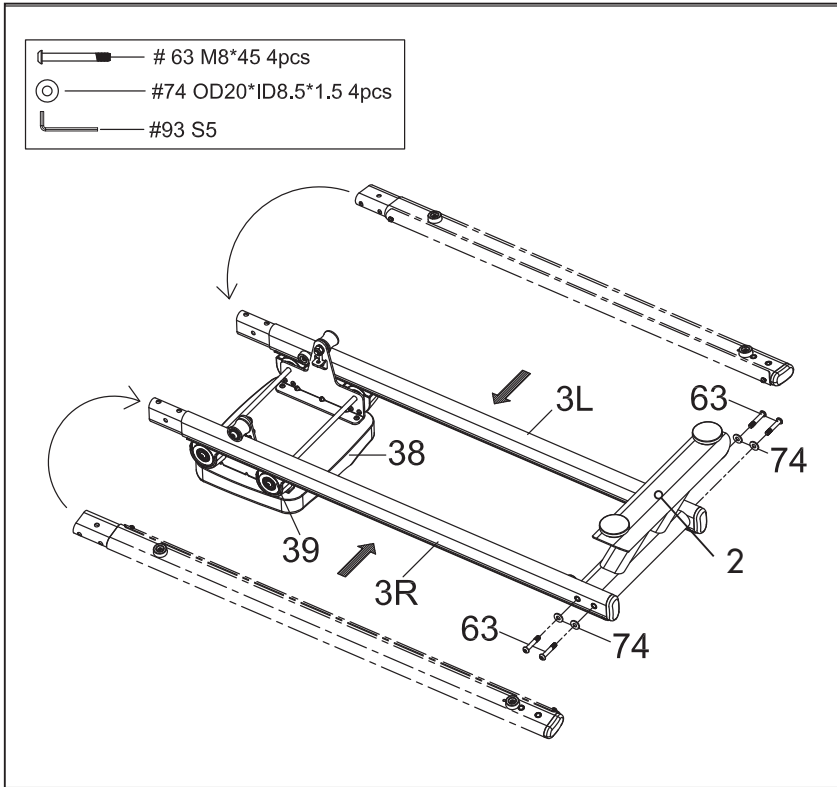

1. Turn over the **Seat (No.38)** as shown. Attach the seat's **Rollers (No. 39)** to the **Slide Rail (No.3L,3R)** making sure the plate touches the rollers. To secure the **Slide Rails (No.3L,3R)** between the **Rollers (No.39)**, you'll need to insert it at an angle and rotate as shown in the diagram to the left.
2. Secure the **Rear Stabilizer (No. 2)** to the **Slide Rails (No. 3)** using 2 **Screws (No. 63)** and 2 **Washers (No. 74)** on both sides.

CRW800H20 STEP TWO

1. This step can be made easier with the use of another person to assist you. Be careful of the sliding **Seat (No. 38)** as it will move when placed upright.
2. Set the **Main Frame (No. 1)** in an upright position and connect the **Slide Rails (No.3)** using 4 **Long Bolts (No. 99)**, 2 **Small Bolts (No. 77)**, and 6 **Screws (No. 65)**.
3. Use the **Allen Wrench (No. 93)** and **Wrench (No. 94)** to secure.

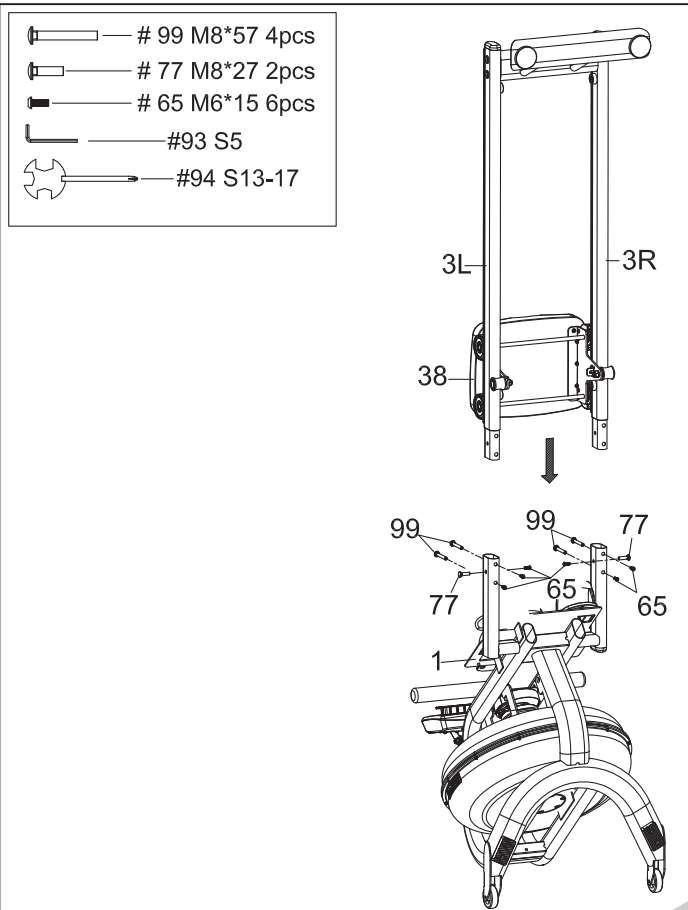

CRW800H20 STEP THREE

1. Connect the **Console Wires (No. 96)** together.
2. Remove the 4 **Screws (No. 67)** from the back of the **Console (No. 54)**. Align the holes on the **Console (No. 54)** with the holes on the **Support Plate (No. 11)** then secure with the screws.

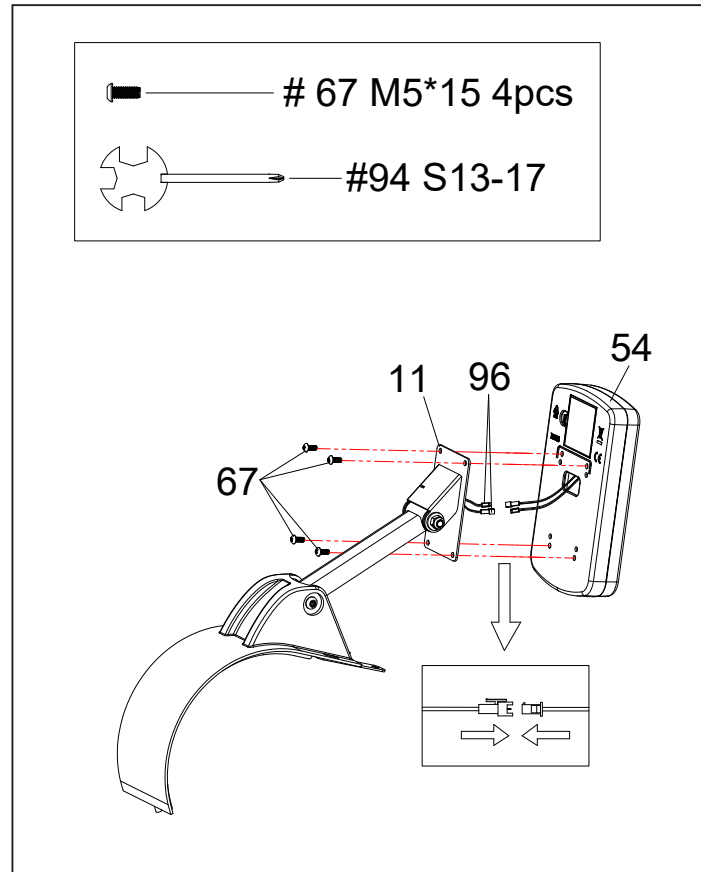

CRW800H2O STEP FOUR

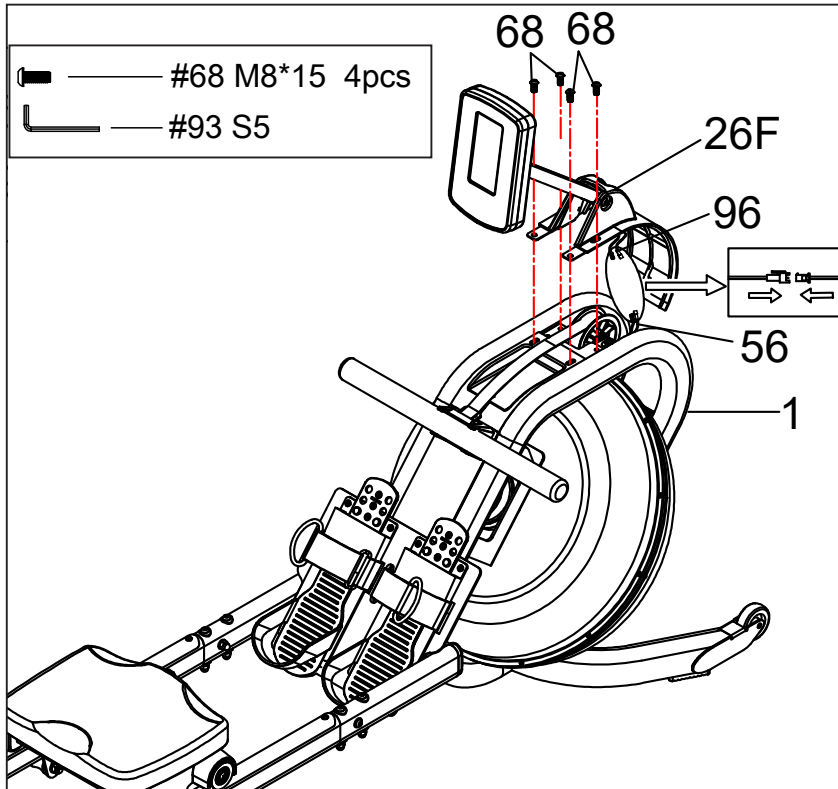

1. Place the 4 AA batteries into the **Console (No. 54)**.
2. Turn the **Main Frame (No. 1)** upright. Connect the **Sensor Wire (No. 56)** to the **Connection Wire (No. 96)**. Be careful not to pinch the wires. Feed any extra length of wire to lay in the **Main Frame (No.1)**.
3. Plug the **Decorative Cover (No. 26)** into the **Main Frame (No. 1)**.
4. Secure the **Console (No. 54)** to the **Main Frame (No.1)** using 4 **Small Screws (No. 68)**.

How to Fill and Empty the Tank

1. Remove the **Fill Plug (No. 50)** from the **Upper Tank (No. 24)**.
2. To fill tank with water, refer to Fig. A. Insert the **Funnel (No. 52)** into the tank, then use a cup or the **Siphon Pump (No. 53)** and a bucket to fill the tank. Use the water level gauge on the side of the tank to measure desired water level in the tank.
3. To empty the tank, refer to Fig. B. Place a bucket next to the rower, and use the **Siphon Pump (No 53)** to pump out the water from the tank into the bucket.
4. Insert the **Fill Plug (No. 50)** into the **Upper Tank (No. 24)**. Wipe excess water off of the frame.

NOTE:

- Fill the tank only with tap water. Add 1 water-purification tablet (1 packet is included.). Never use pool chlorine or chlorine bleach. This will damage the tank and void the warranty.
- Add a water purification tablet every 6 months or as needed. If water remains cloudy, replace the water in the tank.
- Water from the tank is not suitable for consumption. Dispose the water after pumping it out from the tank.

WATER LEVEL

- See Fig. A. The water level gauge is on the side of the tank. The maximum fill level is 6. Never fill it over this limit. Filling the tank over this limit will void the warranty.
- The resistance depends on the water level in the tank. Water level 1 is the lowest resistance. Level 6 is the highest resistance.

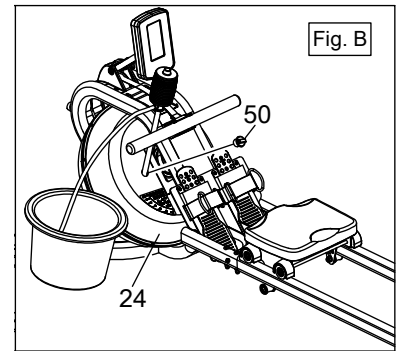
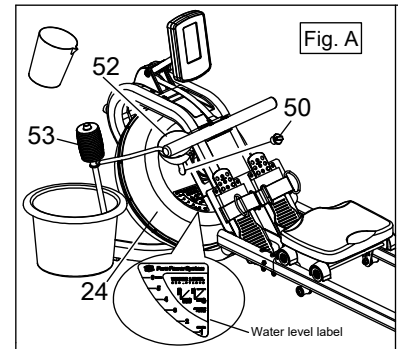

Adjustment Guides

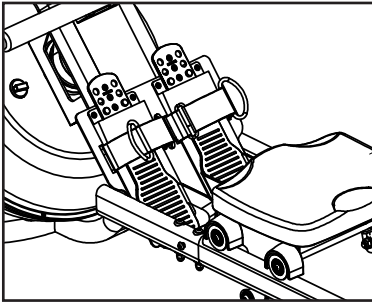

The pedal strap is adjustable and can be personalized to fit the user's foot size.

To adjust the pedal strap, remove the hook and loop end of the strap from the mesh side by pulling it upward and over to the side.

Once removed, you may increase the opening of the pedal strap by pulling the mesh end up and to the side.

To tighten, pull the hook and loop end of the pedal strap upward then over and down to secure it to the mesh side of the strap.

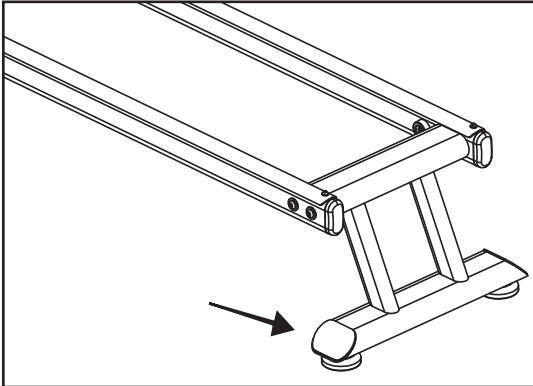

Adjusting the Balance

Adjust the rear feet if the machine is out of balance.

CAUTION!

Moving parts, such as the seat, can crush and cut your fingers. Keep hands clear of the Slide Rail during use.

Storage

To move the machine, lift up the rear stabilizer until the transportation wheels on the front stand touch the ground. With the wheels on the ground, you can transport the rower to the desired location with ease.

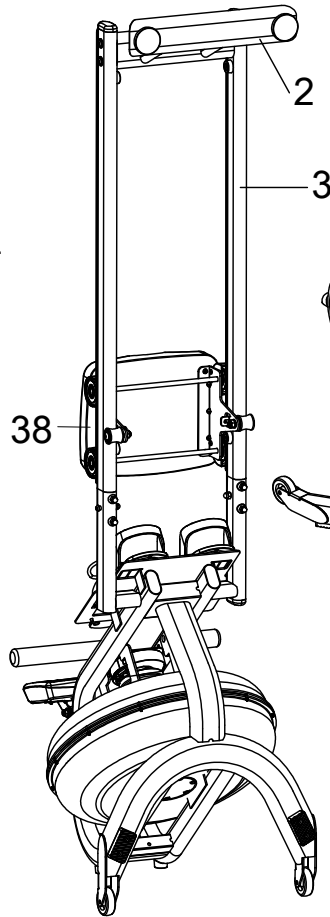

CAUTION!

Move the **Seat (No. 38)** to front of **Slide Rail (No. 3)** first or it will glide down when raising the rower up!

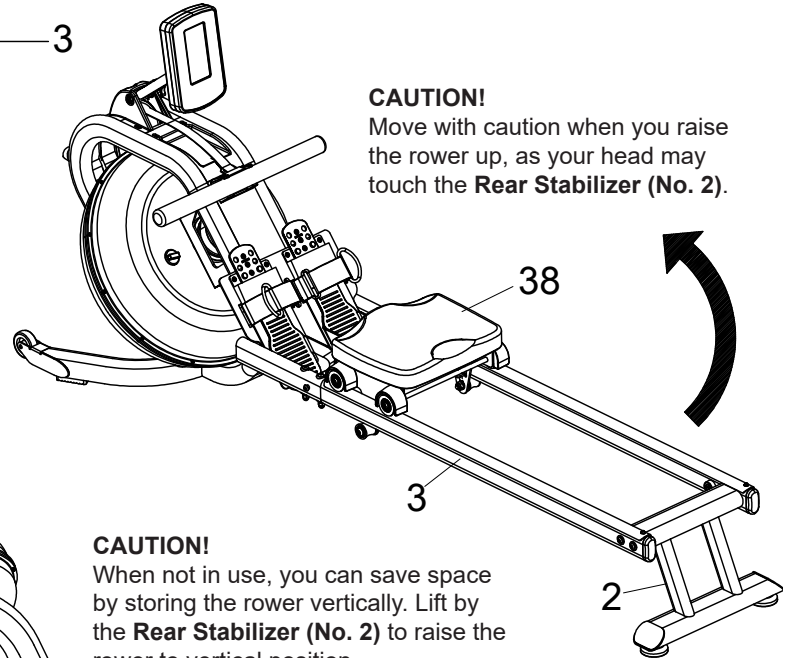

CAUTION!

Move with caution when you raise the rower up, as your head may touch the **Rear Stabilizer (No. 2)**.

CAUTION!

When not in use, you can save space by storing the rower vertically. Lift by the **Rear Stabilizer (No. 2)** to raise the rower to vertical position.

If not using the rower for more than a month, empty the tank before storing.



CRW800H20 CONSOLE OPERATION

INTERVAL DISPLAY
PANEL

QUICK MODE
BUTTONS

QUICK MODE
BUTTONS

TIME, DISTANCE,
CALORIES, WATTS,
SPEED, RPM DISPLAY
PANEL

HEART RATE DISPLAY
PANEL

WATER LEVEL
BUTTON

CONTROL KEYPAD

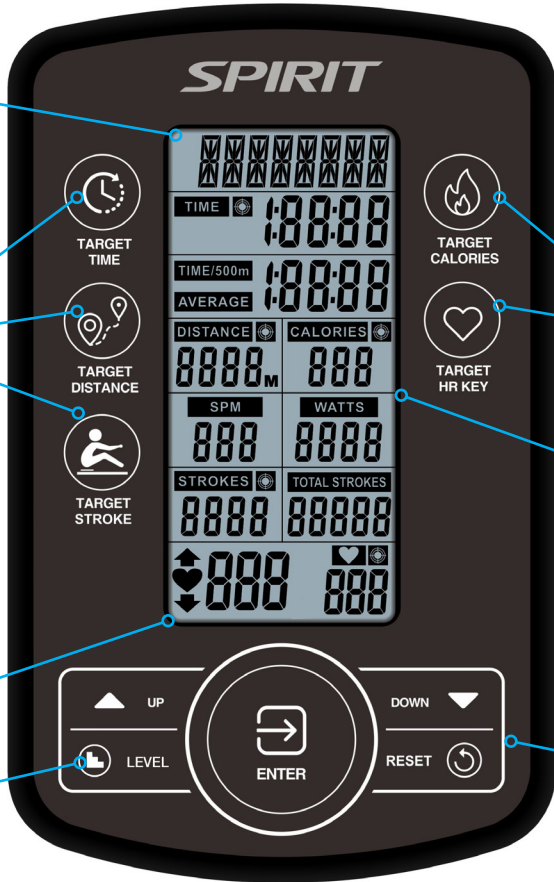

CONSOLE BUTTONS

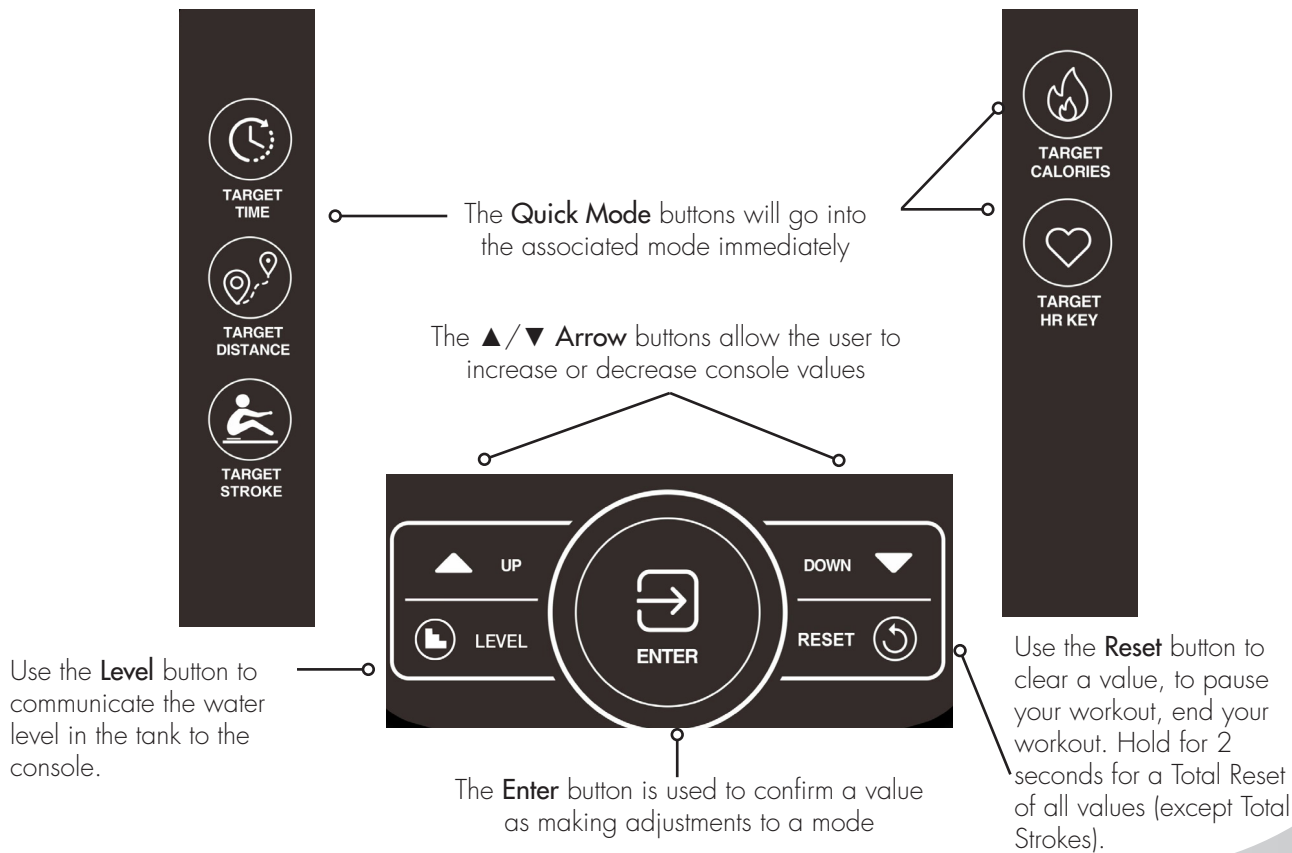

CONSOLE DISPLAY

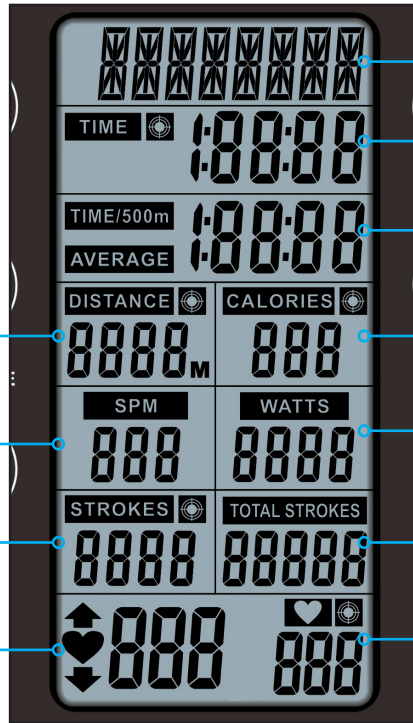

Resistance value displayed here.

When "TARGET TIME" is selected, time selection will be displayed here. Total elapsed time or time count down will be displayed during exercise."

Displays the time needed to row 500 meters according to current speed and average speed.

When "TARGET CALORIES" is selected, calorie selection will be displayed here. Workout data for target calories will be displayed here during exercise.

Displays the power consumption during training.

Displays total accumulative stroke count.

When "TARGET HR" is selected, heart rate value will be displayed here during exercise.

When "TARGET DISTANCE" is selected, distance selected will be displayed here. Overall distance will be displayed during workout.

SPM: Strokes Per Minute

When "TARGET STROKE" is selected, stroke selection will be displayed here. Overall stroke count will be displayed here during exercise."

Heart Rate Value will be displayed here.

TARGET TIME, DISTANCE, CALORIES MODE

The target panels will show Time, Distance, Calories and Strokes depending on operating mode. When the target  symbol is displayed, it means that target mode is operating in that particular value.

The TIME will alternate showing the remaining or elapsed time.

The DISTANCE will count or countdown in meters.

The CALORIES will count or countdown the number of calories burned during workout.

The STROKES will count or countdown the number of strokes during workout.

The TOTAL STROKES show the total number of strokes during workout.

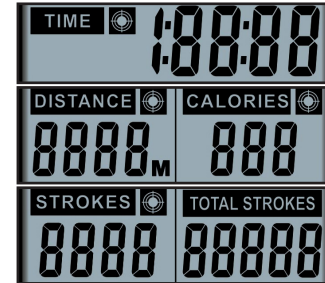

TIME - 500M / AVERAGE DISPLAY

The TIME/500m is time per 500 meters.

The AVERAGE is average time of several TIME/500m work out.



SPM / WATTS DISPLAY

SPM and Watts will be displayed during all modes.

SPM refers to Strokes per Minute.

The WATTS will show the amount of work produced in a particular time during workout.



HEART RATE DISPLAY

This panel will show every user's heart rate information. When console detects a signal from a wireless monitor, the BPM (beats-per-minute) will show in the large three-digit field and the heart icon will flash. However, if no signal is detected, three dashes "---" will display to indicate no heart rate detected.

While in TARGET HEART RATE mode, the console helps the user maintain in a BPM range to build cardiovascular endurance. The target value range will vary by 10% from the default data. The ▼ or ▲ symbol will flash to indicate that an increase or decrease of workout speed is needed to reach the desired range. When the user's heart rate is in the target range, the   icons will light.

To detect heart rate, the heart rate receiver must be installed and a heart rate chest strap (not included) must be used.

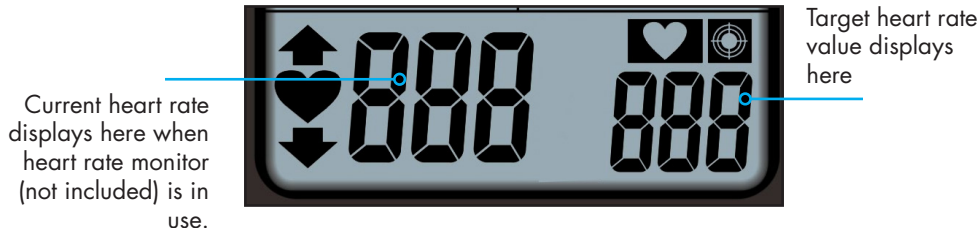

CONSOLE SETUP

BATTERY INSTALLATION

The console operates on 4 AA batteries. The battery compartment is on the back side of the console. Please dispose of batteries properly after use.

WATER LEVEL BUTTON

Once you fill the tank to your desired resistance between 1 and 6 you can use the **LEVEL** Button to communicate the resistance level to the console. Use the arrow keys to adjust from **L1** to **L6**, pressing **ENTER** to confirm the desired level. The default Level is **L1**.

CONSOLE MODES

SLEEP MODE

After 60 seconds of inactivity, the console will switch into the power-saving "Sleep Mode". The display will switch off. Pulling the handlebar or pressing any button on the console will launch the "Ready Mode".

READY MODE

The "Ready Mode" informs the user that the console is powered on and ready to enter into any mode. After a period of 60 seconds of inactivity the console will switch into the "Sleep Mode".

STOP MODE

Press the **RESET** button to go into the "Stop Mode", or if there is no input via the console for 4 minutes the console will automatically enter "Stop Mode". In "Stop Mode", the 7-segment display will show "STOP", TIME will show total time, DISTANCE will show total distance, CALORIES will show total calories burned, STROKES will show the number of strokes for the workout, TOTAL STROKES will show the total number of strokes, TIME/500m and TIME/500m

AVERAGE will be shown alternately for one minute. If heart rates is input, the "Stop Mode" will show current heart rate. If no heart rate monitor has been used, then no values will be displayed.

WORKOUT SUMMARY

The console provides a brief workout summary after completed the workout. Data displayed includes: Total Time, Total Distance and Total Watts.

RESET PROCESS

To reset all saved settings, press and hold **RESET** button for 2 seconds.

CONSOLE PROGRAMS



QUICK START

As strokes are detected, the console will immediately launch QUICK START. TIME, DISTANCE, CALORIES, SPM, WATTS, STROKES, TOTAL STROKES will begin counting. TIME/500m and TIME/500m AVERAGE will be alternately displayed every 5 seconds. The 7-segment display will show level according to the settings. When there's heart rate input, the  icon will stay lit, and the  icon will flash. Current heart rates will be shown. In the absence of heart rate input, three dashes "--" will be shown continuously.

TARGET TIME, DISTANCE, CALORIES, AND STROKES PROGRAMS

Target Time, Target Distance, Target Calories, and Target Strokes program allow the target goal of each value to be customized.

Launch: Press the desired **TARGET** button (TIME, DISTANCE, CALORIES, STROKES).

Setup: When operating a target program (after the console has been reset), user will enter the target value. Adjust the value by pressing  or  buttons, then pressing the **ENTER** button to confirm the setting. If no value has been entered, the console will not count down.

Start: Each mode display field will light up and begin to readout data as follows:

For the TARGET TIME program, the time target will begin to count down.

For the TARGET DISTANCE program, the distance will begin to calculating.

For the TARGET CALORIES program, the calories will begin calculating.

For the TARGET STROKES program, the strokes will begin calculating.

End: The mode will end when the target is achieved. Pressing the **RESET** button at any time will also end the target program. The workout summary will be shown after the target program has ended, or the **RESET** button has been pressed.

TARGET HEART RATE PROGRAMS

The Target Heart Rate program allows the maximum beats per minute (BPM) target to be customized to maximize cardiovascular training.

Launch: Press the **Target Heart Rate** button.

Setup: When operating a target program, the user enters the desired target heart rate (the default is 100). Adjust the value by pressing ▲ or ▼ buttons, then pressing the **ENTER** button to confirm.

Start: The display field will light up and begin to display heart rate and progress toward cardiovascular goal. When the user's heart rate is lower than <10% of the calculated maximum HR range, the ▲ on screen will flash indicating minimum goal has not yet been achieved.

When the user's heart rate is >10% than the target HR, the ▼ on screen will flash to indicate heart rate is over the maximum goal.

When the user's heart rate falls with the 10% of the target HR, the target number will not display.

End: The target program will end when the user stops rowing. Pressing the **RESET** button at any time will also end the target program. The workout summary will be shown after the "Target Program" has ended, or the **RESET** button has been pressed.

ENGINEERING MODE

Press **Reset** and **Enter** buttons for 2 seconds to enter Engineering Mode. The console will also beep for 1 second. DISTANCE banner will blink first. Press ▲ or ▼ button to select setting section. (Sound → ODO → Sound)

While in Engineering Mode if there is no activity for 30 seconds, the console will switch STANDBY Mode. Pressing the **Reset** button will exit the Engineering Mode. The console settings and ODO will not be reset using the "RESET Mode", however, removing the batteries will return the console to original factory settings and the ODO value will be zero.

AUDIO ON/OFF

- Under Engineering Mode of the Audio ON/OFF setting. The SOUND sign will blink. Press **Enter** to get into.
- After pressing **Enter**, the console will display "ON" or "OFF"
 - If the audio is on, the "ON" sign will blink.
 - If the audio is off, the "OFF" sign will blink.
- Press **Enter** to confirm and the console will return to Engineering Mode.
- While in this setting if there is no activity for 30 seconds or pressing **Reset**, the console will switch STANDBY Mode.

ODO

The "ODO" feature displays the total time usage for your machine as H : M : S (hours, minutes, and seconds). Once the time odometer reaches the 2-hour mark, the odometer will begin to display the time in 1-hour increments. For example, "3H" would indicate 3 hours of total usage.

- When cycling through options in "Engineering Mode", press enter when "ODO" is blinking on the display.
- When the total exercise time exceeds 1:59:59, the LCD will display the numerical hour number next to an "H" (hours).
- To exit, press the ▼ or ▲ button to switch between other Engineering modes.
- While in this setting if there is no activity for 30 seconds, the console will enter STANDBY Mode. Pressing the **Reset** button twice will exit the Engineering Mode.

GENERAL MAINTENANCE

A regular preventative maintenance schedule with your fitness equipment ensures that products are working at an optimal condition without affecting the your exercise experience. To assist in the maintenance regimen, it is recommended to break service into daily, weekly, & monthly activities.

All preventive maintenance activities must be performed on a regular basis. Performing routine preventive maintenance actions can aid in providing safe, trouble-free operation of all SPIRIT equipment. SPIRIT is not responsible for performing regular inspection and maintenance for your machines. Be sure to train all necessary personnel in equipment inspection and maintenance actions, in addition to proper accident reporting and record keeping.

Item	Time Frame	Instructions	Notes
Seat and Seat Rails	Weekly	Wipe down seat rails with lint free cloth	
Frame	Weekly	Wipe down frame with lint free cloth	
Tank and Water Treatment	12m to 2years	Follow instructions as specified on page 25 of the manual.	
Rowing Belt	Check every hundred hours for correct tension and for signs of wear.	The rowing belt should provide many years of trouble free use. If a rowing belt change is required, please contact your local service representative for further details.	

SANITIZING YOUR SPIRIT FITNESS EQUIPMENT

- Unupholstered high-contact surfaces (hard plastics) can be sanitized using a 75% isopropyl alcohol solution and a clean, dry cloth. Spray surfaces to be sanitized, and use the dry cloth to wipe clean. Allow surfaces to dry before using.
- For upholstered or soft-plastic surfaces, use a conditioner after sanitizing. Be sure to follow the instructions provided by the conditioner manufacturer to ensure proper use of the conditioner.
- Alternatively, you can make your own spray by mixing the proper ratio of isopropyl alcohol and distilled water to reach a 75% solution.
- For more details on sanitization, or to learn how to make your own spray solution, please visit <https://support.spiritfitness.com/hc/en-us/articles/4406787148564> .

TROUBLESHOOTING

Issue	Possible Cause	Instructions
Water changes color or becomes cloudy	Rower is in direct sunlight or has not had water treatment Local tap water is of poor quality	Change rower location to reduce direct exposure to sunlight. Add water treatment or change tank water as directed on page 25 of this manual. Consider using distilled water to refill tank.
Inconsistent readings on the console for 500meter split time and SPM (strokes per minute)	Sensor gap issue Faulty sensor Sensor has moved out of position Wiring harness issue	Use the back cover of the computer as a "gap tool" to check the gap between sensor head and magnetic ring, or see if the sensor head has moved out of position. Please contact your nearest SPIRIT customer service center for details.
The console does not illuminate after battery installation	Batteries installed incorrectly or need replacing	Check to see if the batteries are installed in the correct position. Reinstall or replace as needed. If the LCD screen fails to illuminate, try rotating the batteries slightly in the computer. If this fails, contact your local service center.
The console screen illuminates, but does not register when rowing	Loose or failed connection Sensor gap too wide	Check that the computer lead is connected properly. If it is connected then contact your local service center. Check sensor gap.

- Please contact your nearest SPIRIT customer service if any assistance is required.

CRW800H2O WATER ROWING MACHINE WARRANTY

EFFECTIVE NOVEMBER 12, 2021

Spirit Fitness warrants all its fitness rower parts for a period of time listed below from the date of retail sale, as determined by sale receipt, or in the absence of a sales receipt eighteen (18) months from the original factory shipping date. Spirit Fitness' responsibilities include providing new or remanufactured parts, at Spirit Fitness' option, and technical support to our independent dealers and servicing organizations. In the absence of a dealer or service organization, these warranties will be administered by Spirit Fitness directly to a consumer. The warranty period applies to the components as follows:

Warranty	Frame	Parts	Labor
Residential	Lifetime	10 Years	2 Years
Commercial (Non dues paying facility.)	Lifetime	5 Years	2 Years

*Prisons and correctional facilities are excluded from warranty coverage.

NORMAL RESPONSIBILITIES OF THE CONSUMER

The consumer is responsible for the items listed below:

- Proper use of the fitness equipment in accordance with the instructions provided in this manual.
- Proper installation in accordance with instructions provided with the fitness equipment and with all local electric codes.
- Proper connection to a grounded power supply of sufficient voltage, replacement of blown fuses, repair of loose connections or defects in house or facility wiring.
- Expenses for making the fitness equipment accessible for servicing, including any item that was not part of the fitness equipment at the time it was shipped from the factory.
- Damages to the fitness equipment finish during shipping, installation or following installation.
- Routine maintenance of this unit as specified in this manual.

EXCLUSIONS

This warranty does not cover the following:

1. CONSEQUENTIAL, COLLATERAL, OR INCIDENTAL DAMAGES SUCH AS PROPERTY DAMAGE AND INCIDENTAL EXPENSES RESULTING FROM ANY BREACH OF THIS WRITTEN OR ANY IMPLIED WARRANTY.
Note: Some states do not allow the exclusion or limitation of incidental or consequential damages, so this limitation or exclusion may not apply to you.
2. Service call reimbursement to the consumer. Service call reimbursement to the dealer that does not involve malfunction or defects in workmanship or material, for units that are beyond the warranty period, for units that are beyond the service call reimbursement period, or for fitness equipment not requiring component replacement.
3. Damages caused by services performed by persons other than authorized Spirit Fitness service companies; use of parts other than original Spirit Fitness parts; or external causes such as corrosion, discoloration of paint or plastic, alterations, modifications, abuse, misuse, accident, improper maintenance, inadequate power supply, or acts of God.
4. Products with original serial numbers that have been removed or altered.
5. Products that have been: sold, transferred, bartered, or given to a third party.
6. Spirit Fitness reserves the right to request proof of purchase if no warranty record exists for the product.
7. THIS WARRANTY IS EXPRESSLY IN LIEU OF ALL OTHER WARRANTIES EXPRESSED OR IMPLIED, INCLUDING THE WARRANTIES OF MERCHANTABILITY AND/OR FITNESS FOR A PARTICULAR PURPOSE.
8. Product used in prisons and correctional facilities

CUSTOMER SUPPORT

If any items need replacement contact the Spirit Fitness Customer Support Department at (870) 935-1107 (Local) or (800) 258-8511. For international customers, please contact your local distributor.

SERVICE

- Keep your bill of sale. Twelve (12) months from the date on the bill of sale or eighteen (18) months from the date of factory shipping as determined by the serial number establishes the labor warranty period should service be required. If service is performed, it is in your best interest to obtain and keep all receipts. This written warranty gives you specific legal rights. You may also have other rights that vary from state to state within the United States. Service under this warranty must be obtained by following these steps, in order:
- Contact your selling authorized Spirit Fitness dealer. OR
- Contact your local authorized Spirit Fitness service organization.
- If there is a question as to where to obtain service, contact our service department at (870) 935-1107. For international customers, please contact your local distributor.
- Spirit Fitness' obligation under this warranty is limited to repairing or replacing, at Spirit Fitness' option, the product through one of our authorized service centers. All repairs must be preauthorized by Spirit Fitness. If the product is shipped to a service center freight charges to and from the service center will be the customer's responsibility. For replacement parts shipped while the product is under warranty, the customer will be responsible for shipping and handling charges. For in-home service, the customer will be responsible for a trip charge. There will be an additional trip charge if the customer is located over 100 miles from the nearest service center.
- The owner is responsible for adequate packaging upon return to Spirit Fitness. Spirit Fitness is not responsible for damages in shipping. Make all freight damage claims with the appropriate freight carrier. **DO NOT SHIP ANY UNIT TO OUR FACTORY WITHOUT A RETURN AUTHORIZATION NUMBER.** All units arriving without a return authorization number will be refused.
- For any further information, or to contact our service department by mail, send your correspondence to:

Spirit Fitness
P.O. Box 2037
Jonesboro, AR 72402-2037

Product features or specifications as described or illustrated are subject to change without notice. All warranties are made by Spirit Manufacturing, Inc. This warranty applies only in the 48 contiguous United States. NOTE: This does not apply to Alaska or Hawaii.

MANUFACTURER

Dyaco Commercial & Medical North America

18303 Bothell Everett Hwy.
Suite 210
Bothell, WA 98012
TEL: +1-425-659-2401 (Local)
TOLL-FREE: +1-866-463-2662
EMAIL: Questions@spiritfitness.com

INTERNATIONAL OFFICES

Taipei HQ Office

12F, No.111, Songjiang
Rd. Taipei City, Taiwan, 10486
TEL: +886-2-2515-2288
FAX: +886-2-2515-9963
EMAIL: info@dyaco.com

Dyaco Japan

Ryogoku ST Bldg. 7F 2-17-17
Ryogoku Sumida Tokyo 130-0026, Japan
TEL: +81 3-5669-0405
FAX: +81 3-5669-0406
EMAIL: info@dyacojapan.co.jp

Dyaco Shanghai

Room 210, No.350
Hengren Road
Yangpu District
Shanghai, China 200438
TEL: 86-21-65068300
FAX: 86-21-65068150

Dyaco UK Ltd

Fairbourne Drive
Atterbury
Milton Keynes
MK10 9RG UK
TEL: +44-0-800 029 3865
EMAIL: sales@dyaco.co.uk

Dyaco Germany

Technologiepark Bergisch-Gladbach
Haus 56
Friedrich-Ebert-Straße 75
51429 Bergisch Gladbach
TEL: +49-0-2204 844 340
FAX: + 49-0-2204 844 333
EMAIL: info@dyaco.de

Dyaco Canada

5955 Don Murie Street
Niagara Falls, ON
L2G 0A9
Canada
TEL: +1 888-707-1880
FAX: +1 905-353-8968
EMAIL: sales@dyaco.ca



800.258.4555
Questions@spiritfitness.com
www.spiritfitness.com



Spirit Fitness
3000 Nestle Road
Jonesboro, AR 72401



CRW800H2O Owners Manual
© 2021 All Rights Reserved
Revision 6: 11.12.2021